

New
Specification



General Certificate of Secondary Education
2018

Centre Number

--	--	--	--	--

Candidate Number

--	--	--	--	--

Mathematics

Unit M3 (With calculator)

Higher Tier



[GMC31]

GMC31

THURSDAY 24 MAY, 9.15am–11.15am

TIME

2 hours.

INSTRUCTIONS TO CANDIDATES

Write your Centre Number and Candidate Number in the spaces provided at the top of this page.

You must answer the questions in the spaces provided.

Do not write outside the boxed area on each page or on blank pages.

Complete in black ink only. **Do not write with a gel pen.**

All working should be clearly shown in the spaces provided. Marks may be awarded for partially correct solutions.

Where rounding is necessary give answers correct to **2 decimal places** unless otherwise stated.

Answer **all twenty-five** questions.

INFORMATION FOR CANDIDATES

The total mark for this paper is 100.

Figures in brackets printed down the right-hand side of pages indicate the marks awarded to each question or part question.

You may use a calculator.

You should have a calculator, ruler, compasses and a protractor.

The Formula Sheet is on page 2.

11724



28GMC3101

Formula Sheet

Volume of prism = area of cross section \times length



Area of trapezium = $\frac{1}{2}(a+b)h$



Volume of sphere = $\frac{4}{3}\pi r^3$

Surface area of sphere = $4\pi r^2$



Volume of cone = $\frac{1}{3}\pi r^2 h$

Curved surface area of cone = $\pi r l$



In any triangle ABC

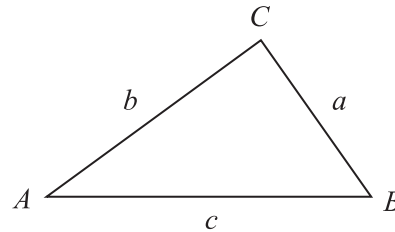

Quadratic Equation

The solutions of $ax^2 + bx + c = 0$
where $a \neq 0$, are given by

$$x = \frac{-b \pm \sqrt{b^2 - 4ac}}{2a}$$

Sine Rule: $\frac{a}{\sin A} = \frac{b}{\sin B} = \frac{c}{\sin C}$

Cosine Rule: $a^2 = b^2 + c^2 - 2bc \cos A$

Area of triangle = $\frac{1}{2} ab \sin C$



1 (a) Write 2 **prime** numbers between 60 and 70

Answer _____ and _____ [2]

(b) Which of these is both a **square** number and a **cube** number?

8 16 36 64 100

Answer _____ [1]

(c) Write $\frac{3}{8}$ as a decimal.

Answer _____ [1]

(d) What percentage is £9 of £16?

Answer _____ % [2]

[Turn over



2 (a) Bikes normally cost $\pounds b$ each.

In a sale they are each reduced by $\pounds 30$

Write an expression for the cost of a bike in the sale.

Answer _____ [1]

(b) Cycling helmets normally cost $\pounds h$ each.

In a sale they are each reduced to half-price.

Write an expression for the cost of a cycling helmet in the sale.

Answer _____ [1]

(c) Write an expression for the total cost of 4 bikes and 4 cycling helmets in the sale.

Answer _____ [2]

3 Solve the equation $5y + 4 = 24$

Answer _____ [2]



- 4 The packaging for a tube of toothpaste is a cuboid measuring $16\text{ cm} \times 5\text{ cm} \times 4\text{ cm}$.

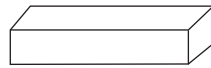

The manufacturer wants to be able to pack 150 of these tubes into a cardboard box.

The box is a cuboid.

The box measures $48\text{ cm} \times 35\text{ cm} \times 28\text{ cm}$.

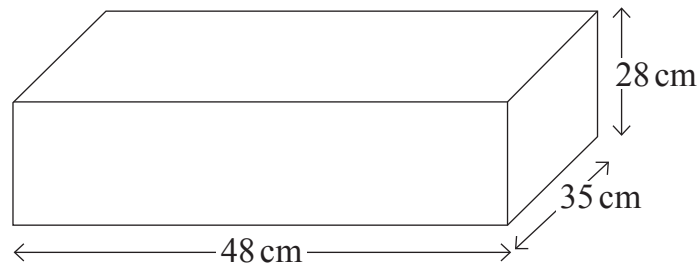

Will the box be big enough to hold 150 tubes of toothpaste in their packaging?
You must show working to explain your answer.

Answer _____ [3]

[Turn over



5 Male and female care assistants work in a nursing home.

Some can work weekdays only, some can work weekends only and some can work both.

(a) Complete the two-way table below.

	Weekdays only	Weekends only	Both	Total
Male	1			8
Female		3		
Total	3		10	21

[2]

(b) How many male care assistants can work on weekends?

Answer _____ [1]



6 John has a telephone with the following costs.

Line rental: £18.99 per month

Call charge: 5.8p per minute

Last month John made calls lasting 385 minutes.

Work out his telephone bill for last month.

Answer £ _____ [3]



7

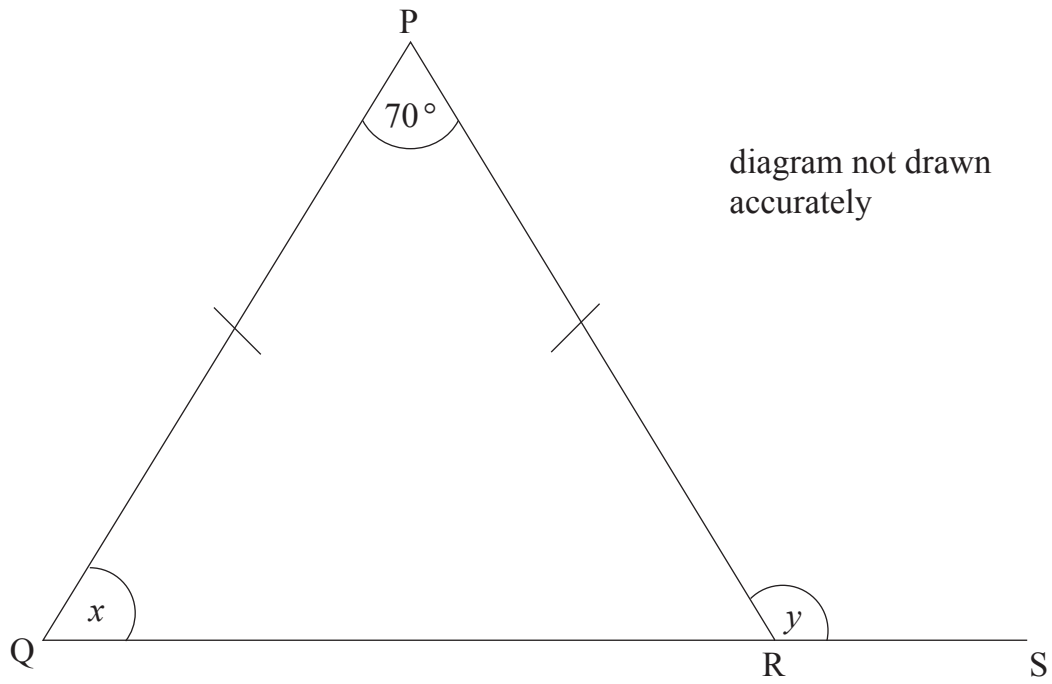

PQR is an isosceles triangle with $PQ = PR$.
QRS is a straight line.

(a) Work out the size of the angle marked x .

Answer _____ $^{\circ}$ [2]

(b) Work out the size of the angle marked y .

Answer _____ $^{\circ}$ [1]



(c)

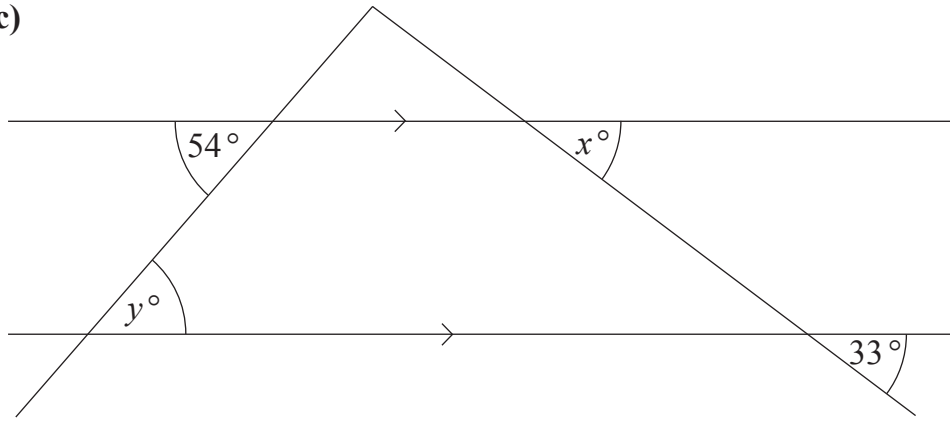

diagram not
drawn
accurately

Write down the values of x and y .

Answer $x =$ _____ [1]

Answer $y =$ _____ [1]



- 8 The life expectancy for males in 12 countries in Africa for 2015 is shown in the following stem and leaf diagram.



Key: 5 | 3 means 53 years

- (a) How many of these countries had a life expectancy for males of less than 58 years?

Answer _____ [1]

- (b) For the above data work out

- (i) the median,

Answer _____ years [1]

- (ii) the range.

Answer _____ years [1]



(c) In **1975** the life expectancy for males in the same 12 countries had a median of 49 years and a range of 30 years.

Compare the life expectancy for males in these 12 countries in **2015** with the life expectancy for males in **1975**

[2]

[Turn over



9 Sue is training to compete in a 10 km walk.

A diagram of her local athletics track is shown below.

The track consists of a rectangle and two semicircles.

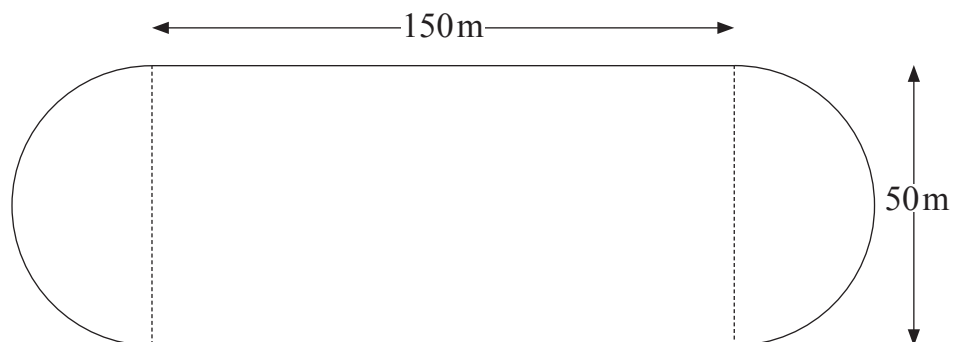

diagram
not
drawn
accurately

How many complete laps are needed to ensure she walks 10 km?

You must show all your working.

Answer _____ [4]



10 (a) Pat buys 30 boxes of crisps.

Each **box** contains 48 **packets** of crisps.

He sells 80% of the crisps at 60p a packet.

(i) How many packets does he sell at this price?

Answer _____ [2]

(ii) How much in total does he sell them for?

Answer £ _____ [1]

(b) He sells the rest at 20p a packet.
Pat paid £25 for each box of crisps.

Does Pat make a profit or loss, and how much is this profit or loss?

Answer Pat makes a _____ of £ _____ [3]

[Turn over



- 11 A group of pupils do a first aid course over 8 nights.
There is a test at the end of the course.

The table shows the number of nights each pupil misses and their test score.

Pupil	A	B	C	D	E	F	G	H	I	J
Number of nights missed	0	3	1	3	2	1	0	5	1	5
Test score	92	64	90	68	80	82	86	42	76	46

- (a) The first 4 points are plotted on the scatter graph.
Plot the last 6 points.

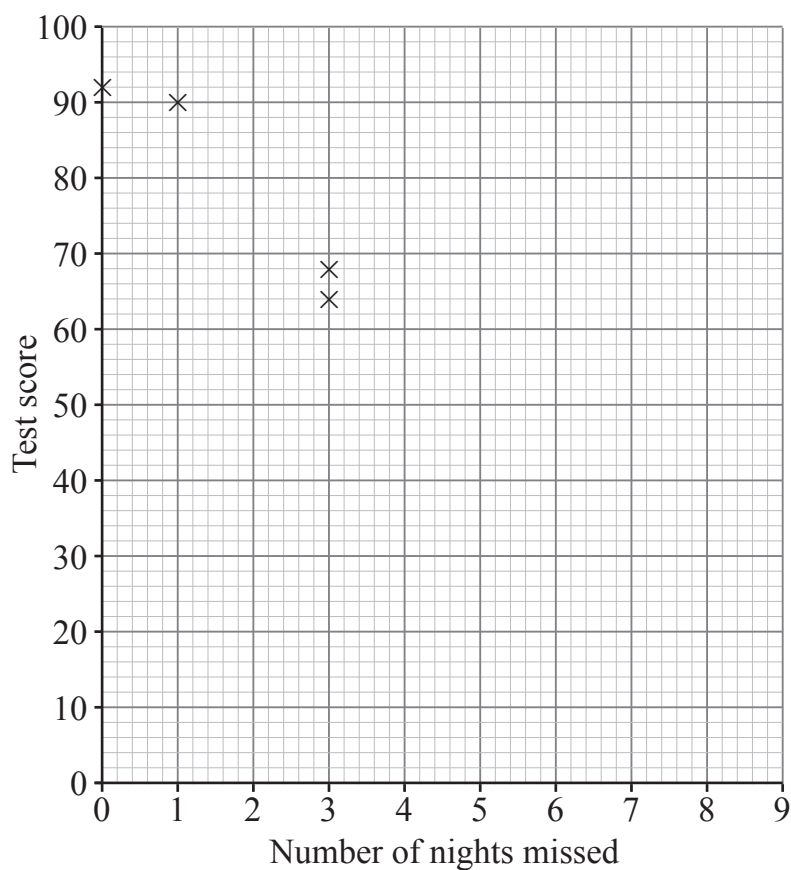

[2]



(b) Draw the line of best fit. [1]

(c) Another pupil missed 4 nights of the course.
Use the graph to estimate their test score.

Answer _____ [1]

(d) What type of correlation does your graph show?

Answer _____ [1]

[Turn over



12 Each player in a group of 15 players scored either 2 or x goals.

Number of goals	Frequency
2	10
x	5

The mean number of goals per player was 3

Calculate x .

Answer $x =$ _____ [3]



13 A garden has a flowerbed in the corner.

A diagram of the garden is shown below.

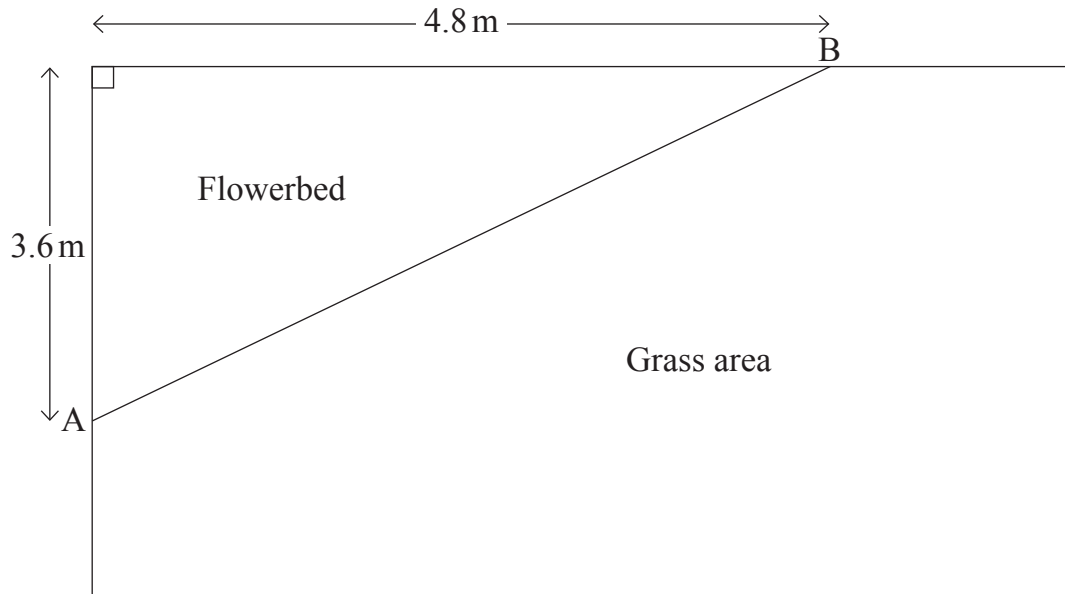

(a) Calculate the area of the flowerbed.

Answer _____ m² [2]

(b) There is a small fence along the line AB separating the flowerbed from the grass area.

How long is the fence?

Answer _____ m [3]

[Turn over



14 Last year a company spent a total of £2400 on advertising.

This year they spent £2796

What was the percentage increase in their spending on advertising?

Answer _____% [3]

15 Solve the equation $p + 15 = 2(4p - 3)$

Answer $p =$ _____ [3]



16 Best Bank offers a 3 year investment account with a fixed compound interest rate of 1.75 % per annum.

Mr Lucas invests £8000 in this account.

What is the value of his investment at the end of the 3 year period?

Answer £ _____ [4]

[Turn over



17 At a concert 40% of the audience are children.

One third of the **rest** of the audience are men.

There are 120 women in the audience.

Work out the total number of people in the audience.

Answer _____ [3]



18 A cylindrical tank has a diameter of 80 cm and a height of 150 cm as shown.

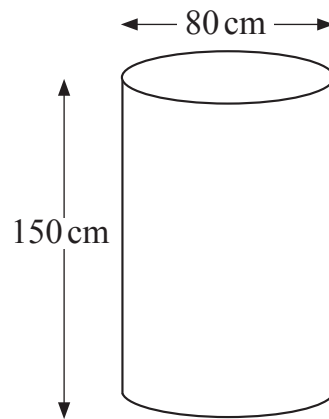

Calculate the volume of water the tank can hold when full.

Give your answer correct to the nearest litre.

Answer _____ litres [4]



19 Peter, John and Matthew are three brothers.

Peter is 10 years old.

John is x years old.

Matthew is a year younger than twice John's age.

The mean of their ages is 7 years.

Work out John's age.

Answer _____ [4]



20 Which average (mean, mode or median) would be most suitable for each set of data?

Explain your choice.

- (a) One value appears much more frequently than the others and it is not at the upper or lower end of the data.

Answer _____ because _____

_____ [1]

- (b) The data is fairly evenly spread but there is one extreme value at the upper end.

Answer _____ because _____

_____ [1]

[Turn over



21 A school timetable is being arranged.

The day can be arranged in 30-minute classes or 50-minute classes or 60-minute classes.

No matter which of the three choices is made, the total daily teaching time will be the same.

Ignoring the time for break or lunch, what is the daily teaching time?

You must show all your working.

Answer _____ [4]



22 Solve the equation

$$\frac{2x - 1}{3} + \frac{x + 2}{2} + \frac{x}{6} = 8$$

Show all your working clearly.

A solution by trial and improvement will not be accepted.

Answer $x =$ _____ [5]

[Turn over



23 Factorise $y^2 - 6y + 8$

Answer _____ [2]

24 A rectangle and a square have the same length of diagonal.

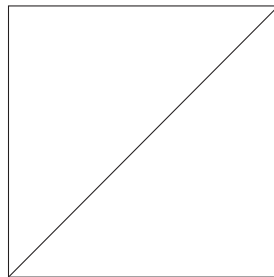
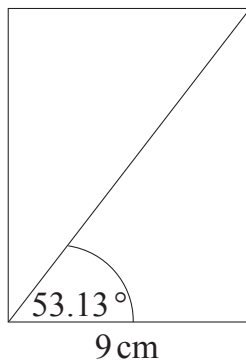

diagrams
not
drawn
accurately

Calculate the length of the side of the square.

Give your answer correct to 1 decimal place.

Answer _____ cm [6]



25

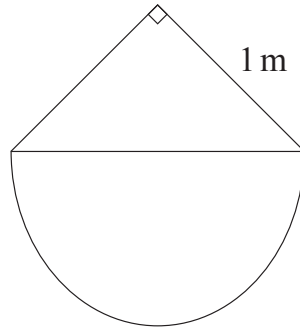

diagram not
drawn accurately

The composite shape consists of a right-angled isosceles triangle and a semicircle.

(a) Show that the area of the composite shape is approximately 1.285 m^2

[4]

(b) Find the force applied to the area of the composite shape when the pressure is 5 N/m^2

Answer _____ N [2]

THIS IS THE END OF THE QUESTION PAPER

11724



28GMC3127

DO NOT WRITE ON THIS PAGE

For Examiner's use only	
Question Number	Marks
1	
2	
3	
4	
5	
6	
7	
8	
9	
10	
11	
12	
13	
14	
15	
16	
17	
18	
19	
20	
21	
22	
23	
24	
25	

Total Marks	
--------------------	--

Examiner Number

Permission to reproduce all copyright material has been applied for.
In some cases, efforts to contact copyright holders may have been unsuccessful and CCEA will be happy to rectify any omissions of acknowledgement in future if notified.

11724/4



28GMC3128